

405 Kg/24h

Fabbricatori di ghiaccio modulare / Modular Ice Makers:
M145 F - M195 F - M205 F - M305 F - M405 F - M505 F
M145 - M195 - M205 - M305 - M405 - M505

M405 ALL GAS
230V/1N/50Hz
Modular Ice Makers



CARATTERISTICHE

- Scocca in acciaio
- Condensazione ad aria o acqua
- Ciclo di sanificazione
- Tasto comandi capacitivo
- Segnalazione acustica e luminosa allarmi
- Report allarmi HACCP
- Regolazione peso cubetto esterna
- Collegamento USB per aggiornamento sw e scarico dati HACCP
- Ventilatore condensatore controllato alle basse temperature ambiente
- Produzione ghiaccio programmabile
- Analisi predittiva malfunzionamenti
- Report prestazioni apparecchiatura.



OPZIONALE

- Ciclo sanificazione programmabile con Ozono
- Trattamento nanotecnologico evaporatore con Rainbow technology
- Connessione cloud IOT
- Regolazione livello ghiaccio deposito

FEATURES

- Stainless steel construction
- Air or water condensation
- Sanitization cycle
- Capacitive button
- Acoustic and luminous alarms
- Report HACCP alarms
- External cube weight adjustment
- USB connection for software update and HACCP data download
- Condenser fan controlled at low ambient temperatures
- Programmable ice production
- Predictive analysis of malfunctions
- Machine performance report.

OPTIONAL

- Sanitization cycle programmable with Ozone
- Rainbow technology Nanotechnological evaporator treatment
- IOT cloud connection
- Storage bin ice level adjustment

DATI TECNICI - SPECIFICATIONS

		cond	comp. W	ABS. W	Fuse	Kwh/100Kg	I / h	kg	kg
M405	A AG		5218	2100	16	12.5	18.4	88	106
M405	W AG		5218	1950	16	10.7	136	83	101

TIPO GHIACCIO / ICE TYPE

	PCS / CYCLE	WEIGHT ICE
	PZ/CICLO	PESO GHIACCIO
HALF-LARGE 10X29X24 mm	555	6 g
DICE 22X22X24 mm	342	10 g
LARGE 29X29X24 mm	210	17 g

PRODUZIONE GHIACCIO / ICE PRODUCTION

kg/24h
lbs/24h

Raffreddamento ad Aria
Air Cooled Unit



Temp. Aria Air Temp.	Temp. Acqua / Water Temp.			
°C	32°	21°	15°	10°
°F	90°	70°	60°	50°
10°	330	365	390	400
50°	727	804	860	882
21°	300	330	350	360
70°	661	727	771	793
32°	240	265	272	280
90°	529	584	599	617
38°	185	210	217	225
100°	408	463	478	496

Raffreddamento ad Acqua
Water Cooled Unit



Temp. Aria Air Temp.	Temp. Acqua / Water Temp.			
°C	32°	21°	15°	10°
°F	90°	70°	60°	50°
10°	269	300	317	322
50°	593	661	699	710
21°	245	275	293	297
70°	540	606	646	655
32°	226	259	271	278
90°	498	571	597	613
38°	217	250	261	269
100°	478	551	575	593

Via del Lavoro, 9 31033 Castelfranco Veneto (TV) Tel.
+39 0423.738452 Fax +39 0423.722811
email: info@castelmac.it
www.castelmac.eu - www.icematic.eu

405 Kg/24h

Fabbricatori di ghiaccio modulare / Modular Ice Makers:
M145 F - M195 F - M205 F - M305 F - M405 F - M505 F
M145 - M195 - M205 - M305 - M405 - M505

M405 ALL GAS
230V/1N/50Hz
Modular Ice Makers

DIMENSIONI - DIMENSIONS

Vista frontale
Front view

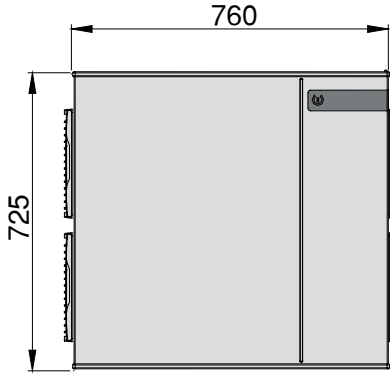

Vista laterale
Lateral view

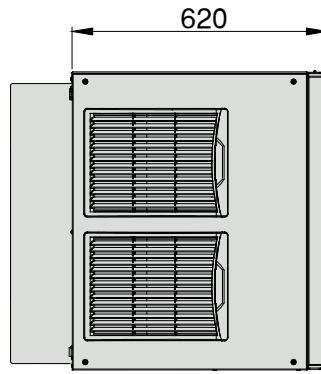

Vista superiore
Top view

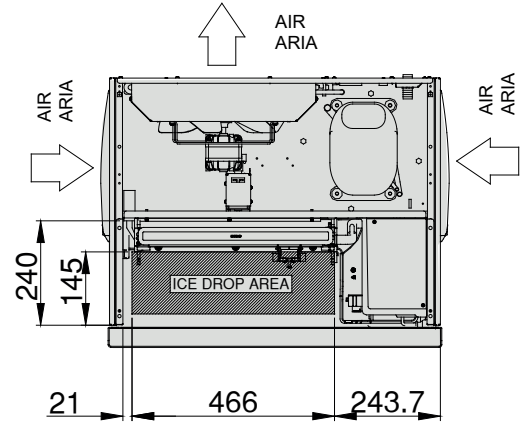

Vista Posteriore
Back view

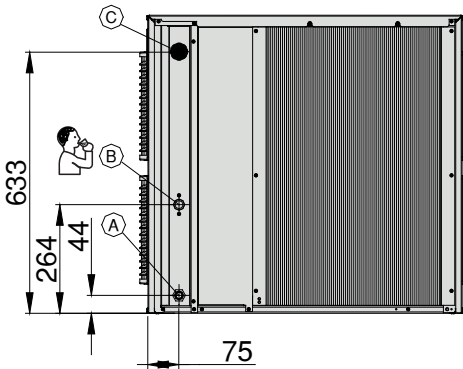

Vista Posteriore
Back view

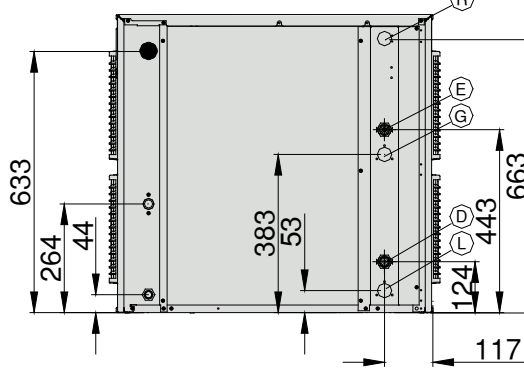

- A** Scarico acqua Ø 20mm
Water drain Ø 20mm
- B** Ingr. acqua potabile 3/4 GAS
Potable water inlet 3/4 GAS
- C** Ingresso alimentazione elettrica
Electrical cable supply

- D** Ingresso acqua cond. 3/4 GAS
Condenser water inlet 3/4 GAS
- E** Uscita acqua cond. 3/4 GAS
Condenser water outlet 3/4 GAS
- G** Mandata gas linea split 1/2"
Discharge gas split line 1/2"
male quick connection

- L** Aspirazione gas linea split 1/2"
connessione rapida maschio
Suction gas split line 1/2"
male quick connection
- R** Connessione alimentazione per
ventilatore condensatore remoto
Remote electrical connection
for condenser fans

TOUCH CONTROL

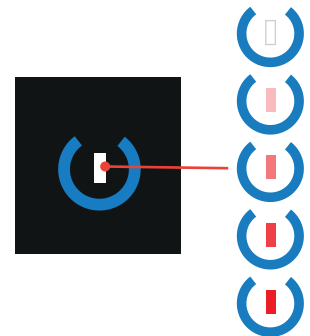

Capacitive Stand-by / Start button
(led continuous variation colors from white to red)

Tasto Capacitivo di Stand-by / Avvio
(led a variazione continua di colori dal bianco al rosso)

APP ALLGAS SYSTEM

Permette il comando e il monitoraggio dei produttori di ghiaccio direttamente da smartphone / It allows the control and monitoring of the ice machines directly from a smartphone

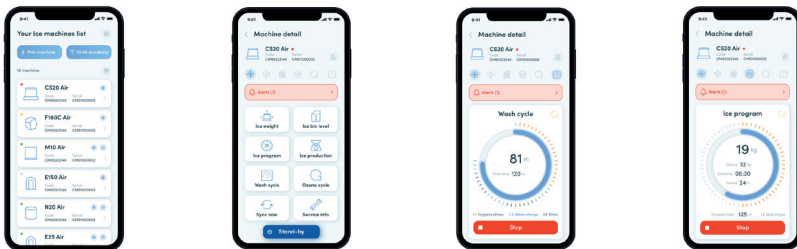

Condizioni operative - Operating requirements

	Min.	Max
Temp. Ambiente / Air Temperature	10°C	40°C
Temp. Acqua / Water Temperature	5°C	35°C
Press. Acqua / Water Pressure	1 Bar (14psi)	5 Bar (70psi)
Conducibilità acqua / Water conductivity	20 µS	500 µS
Alimentazione / Electrical supply	-10%	+10%

Calore espulso / Rejected Heat	7128 W
Volume Aria / Air Volume	1180 m ³ /h

Via del Lavoro, 9 31033 Castelfranco Veneto (TV) Tel.
+39 0423.738452 Fax +39 0423.722811
email: info@castelmac.it
www.castelmac.eu - www.icematic.eu